

DATOS DE PEDIDO

Razón Social			
Fecha		Referencia	
L1 (mm)	L2 (mm)	T1 (mm)	T2 (mm)
Unidades		Unidades	
Tfno contacto		Servicio entrega	

DATOS DE ENVIO

Nombre	
Dirección	
Población	C.P.
Provincia	País

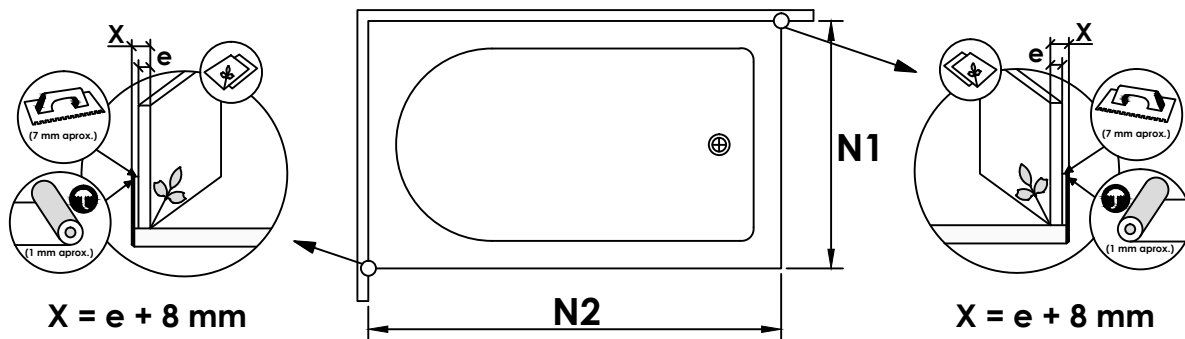

Detalle a tener en cuenta para establecer las medidas de L1, L2, T1 y T2

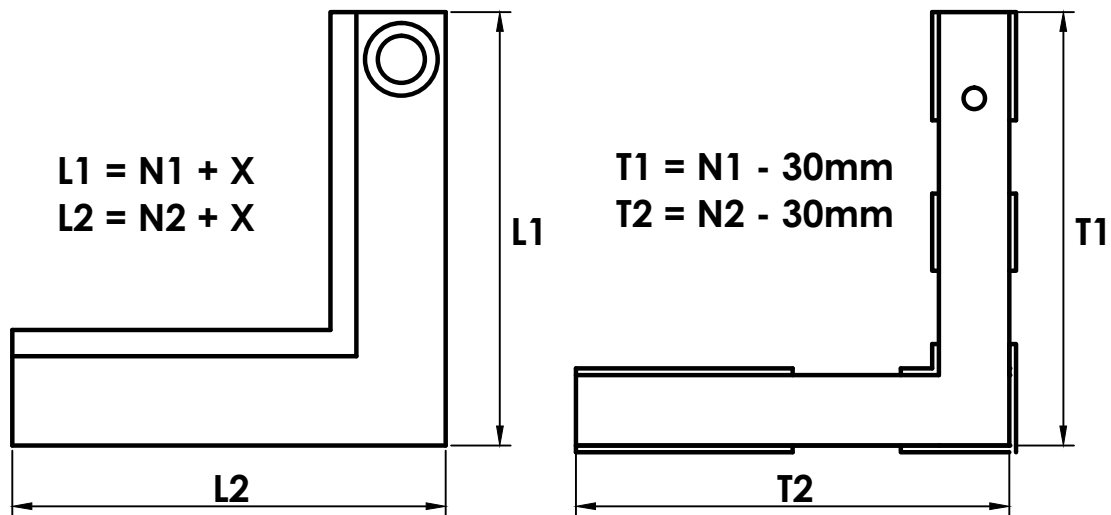

Referencia artículo	Se sirve cortado a medida entre
Basic BED 1000	750 / 1000
Basic BED 1250	1000 / 1250
Basic BED 1500	1250 / 1500
Basic BED 1750	1500 / 1750
Basic BED 2000	1750 / 2000
Basic BED 2250	2000 / 2250
Basic BED 2500	2250 / 2500
Basic BED 2750	2500 / 2750
Basic BED 3000	2750 / 3000